

NIIMBOT

Product Manual

Smart Label Printer

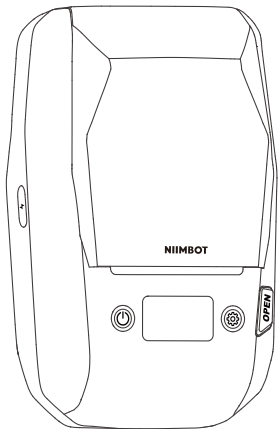

NIIMBOT M2

01

Package Contents



Smart Label Printer *1



USB Type-C Cable *1



Label Paper Roll *1



Thermal Transfer Ribbon *1

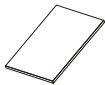

Product Manual *1

02

Specifications

Product	Label Printer	Model	NIIMBOT M2_H
Dimensions	108*178*74mm	Weight	764g
Charging Time	2 - 3 hours	Input	5V DC, 2A
Battery Capacity	2000mAh	Printing Method	Thermal Transfer Printing
Printing Resolution	300dpi	Printing Width	48mm
Connectivity	Bluetooth、Type-C	Charge	Type-C
Transmit Power	4dBm(Maximum)	Operating Temperature	0°C - 40°C

03

Product Description

03-1 Label Printer

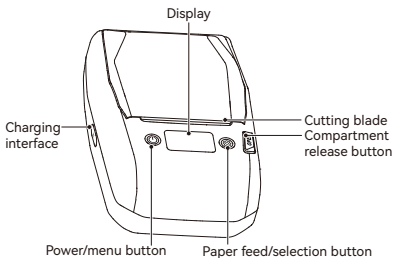

03-2 Carbon ribbon area

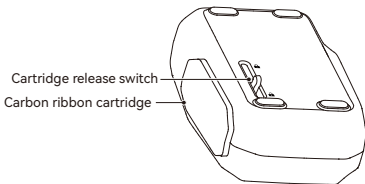

04

Operating Instructions

04-1 Loading paper

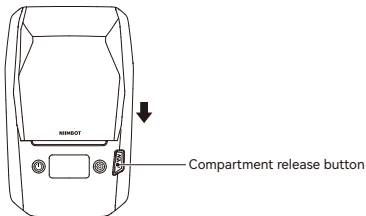

- 1 Press the compartment release button.

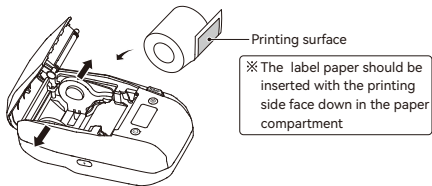

- 2 Open the roll holders and load the label paper.

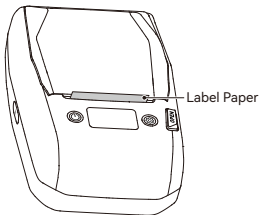

- 3 Pull the label paper out of the paper compartment and close the paper compartment cover.

04-2 Installing the carbon ribbon

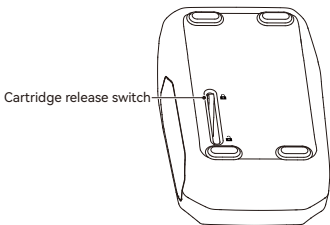

- 1 Unlock the carbon ribbon cartridge.

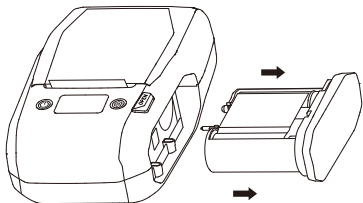

- ② Remove the old carbon ribbon cartridge.

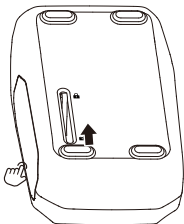

- ③ Insert a new carbon ribbon cartridge. Press the carbon ribbon cartridge with one hand and slide the release switch with the other hand to lock it in place.

04-3 Download software

01.Download the NIIMBOT APP

To use this product, please download and install the NIIMBOT app, available from Google Play or the App Store on Apple devices.



NIIMBOT

Design & Print APP
easy to download and use



※ More instructions can be viewed in the NIIMBOT app

Sign in to NIIMBOT ▶

Me ▶

Help Center ▶

Hardware

02.Download the “NIIMBOT” Desktop Version

Visit the software downloads page on NIIMBOT's official website (www.niimbot.com) to download and install the computer version of "NIIMBOT".

※ Note: To connect a computer to this device, please use the officially provided data cable or a data cable that supports data transmission.

04-4 Printing Label

- 1 Once the app has downloaded, make sure your phone's Bluetooth is turned on.
※ Note: Location permissions may need to be enabled on Android phones.



Turn on Bluetooth

- 2 Open the app and search for Bluetooth devices to connect to.
※ Note: If it asks for a PIN, enter 0000 or 1234 then press OK.
- 3 Once successfully connected, go to the Drawing Board.

Note

The illustrations of products, accessories, software interfaces, etc. in this getting started guide are illustrative in nature and for reference only. Due to product updates and upgrades, the physical product may differ slightly from the illustrations. Please refer to the actual physical product in such case. The product is subject to technical improvements without notice.



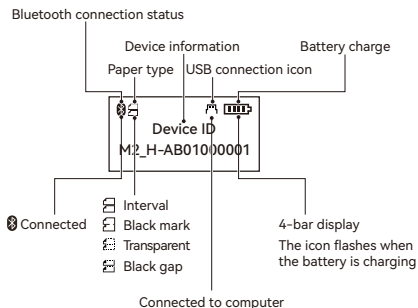

05

Control panel

05-1 User interface



Paper types

-  **Interval:** There is a space between two label sheets.
-  **Black mark:** Two label sheets are connected, and there is a black mark on the back of the label paper.
-  **Transparent:** The label paper is made from a transparent material.
-  **Black gap:** There is a space between two label sheets, and there is a black mark on the back of the label paper.

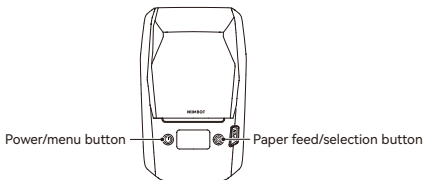

05-2 Operating Instructions

1. Power/menu button: For selecting the function menu.
2. Paper feed/selection button: For selecting functions.

05-3 Function description

Level 1 menu	Level 2 menu	Level 3 menu	Description
Paper Calibration	---	---	Use this function to calibrate the paper in the event of a paper feed fault.
Print density	1, 2, 3, 4, 5	---	Set the density of printed content
Print testing page	---	---	Print device and material information
Automatic power-off	15 minutes 30 minutes 60 minutes Never	---	Set the automatic power-off time

Level 1 menu	Level 2 menu	Level 3 menu	Description
Printer information	Hardware version no., firmware version no., Bluetooth MAC address	---	The printer's hardware and firmware version numbers
Advanced settings	Language	Simplified Chinese/ Traditional Chinese/ English	Set the language for the onscreen content
	Paper type	Interval Black mark Transparent Black gap	Set the type of label paper you are using.
	Restore factory settings	---	Restore to factory settings with one touch

06

Care and maintenance

06-1 Charging

- Make sure the product and your hands are dry. Plug the Type-C charging cable into the charging port, connect the power adapter, then plug the power adapter into a mains outlet.
- When the battery is empty (0 bars), the device will display "Insufficient battery charge, please charge" and switch off automatically after 10 seconds. Recharge the battery before using the printer again.
- A full charge takes 2-3 hours.
- For optimal performance, charge the battery at least once every 2-3 months.



To prolong the battery life, we do not recommend printing while charging.

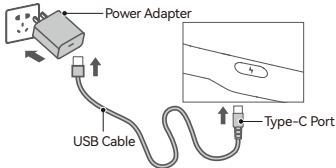

06-2 Cleaning the printhead and rubber roller

Clean the printhead and rubber roller if any of the following occurs:

- Printing is not clear
- The printer makes a loud noise while feeding and ejecting paper
- Foreign matter is adhered to the printhead

The steps for cleaning the printhead and rubber roller are as follows:

- ① Turn off the power supply.
- ② Open the paper compartment cover and find the printhead (see diagram). If printing has just finished, wait for the printhead to cool completely.
- ③ Rotate the rubber roller while simultaneously using a cotton ball dabbed with alcohol (which should be wrung dry) to scrub dust and stains from the surface.
- ④ Use a cotton ball dabbed with alcohol (which should be wrung dry) or a specialized printhead cleaning brush (available separately) to scrub dust and stains from the surface of the printhead.
- ⑤ Wait 5-10 minutes for the alcohol to completely evaporate, then close the paper compartment cover.

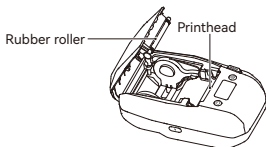

06-3 FAQs

Q: Why do I need to enable location permissions on my mobile phone?

A: On Android devices, you must enable location permissions to use Bluetooth.

Q: What is my PIN number?

A: For Android devices, the default pin number is usually 0000, 1234, or sixteen 0s.

Q: Why can't I find the printer on my mobile device?

A:

1. Make sure that Bluetooth is enabled on your mobile device.
2. Restart the printer or the app, then search again.
3. Disable Bluetooth on your mobile phone and then re-enable it.

Q: What should I do if Bluetooth pairing failed?

A:

1. Restart the printer or the app, then search again.
2. Disable Bluetooth on your mobile phone and then re-enable it.

Q: What should I do if the printed content isn't clear?

- A:** 1. Press the power button once to feed one sheet, then print again.
2. Press the power button twice to print a self-testing page, then take a picture of the testing page and send it to Customer Service for further analysis.

Q: When I tap to print, no content appears and the device makes a continuous clicking sound?

- A:** 1. Check that the label paper is properly loaded and protruding from the printer.
2. Check whether the printer is out of label paper or carbon ribbon and replace if necessary.

Q: What should I do if printing stops unexpectedly?

- A:** Follow the in-app prompts to resolve the issue.

Q: What should I do if the printed content is offset?

- A:** 1. Check whether the label paper dimensions are consistent with the app template.
2. Adjust the printing offset through the app editing functions.

Q: What should I do if there is a paper feed error?

- A:** 1. Check whether the label paper or foreign matter is stuck to the sensor in the paper guide groove.
2. Check whether the dimensions in the app template settings are consistent with the actual dimensions of the label paper.

3. Check that you selected the correct paper type in the template.
4. On the paper feed calibration page, press the "Paper feed/selection" button to calibrate the paper feed.
5. If the issue persists, there may be a problem with the sensor. Contact Customer Service for assistance.

Q: What should I do if the carbon ribbon is wrinkled?

A: Pull out the carbon ribbon and rotate it clockwise or counterclockwise until the ribbon is pulled tight.

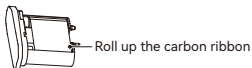

07

Safety Precautions

Read all instructions and warnings in this guide carefully before using the product to ensure proper and safe use of the product and to avoid personal injury or damage to property.

*Warning



Do not disassemble the product yourself. No returns or exchanges will be authorized for disassembled products.



Do not use corrosive chemical products or cleaners to wipe down the product.



Do not use the product in the vicinity of flammable substances such as in gas stations, fuel depots, etc.

1. Keep the product and accessories in a safe place that is inaccessible to children, or only allow use under the supervision of a guardian.
2. Immediately disconnect the product from the power source if the product enters water.
3. Immediately disconnect the product if the device malfunctions.
4. If you use a power adapter to charge (or power) the device, you must purchase an adapter that is safe, compliant, and meets the standards.
5. Do not disassemble the product to replace the battery yourself. Incorrectly replacing the battery can result in an explosion.

6. The battery contains special protective circuitry and devices. Do not disassemble the battery as this may cause short circuits or electrolyte leakage. If electrolytes accidentally enter your eye, rinse immediately with clean water and seek medical advice.
7. Do not expose the appliance or power adapter to high-temperature or high-humidity environments, or put in water, to prevent short circuits that can cause the battery to become hot, smoke, deform, get damaged or even explode.
8. Disconnect the power adapter immediately if you notice either smoke or a smell coming from the product or the power adapter, taking care to avoid burns.

***Important**

Please purchase the version of the product that matches your region or country of use through the NIIMBOT official store or a NIIMBOT authorized sales agent. Purchasing the product through other channels may mean you buy a pirated product or a product not adapted to your region or country of use which may lead to usage issues. In such cases, NIIMBOT may be unable to provide you with further assistance.

Notice: If the device cannot be turned on, please charge for one hour.

Wuhan Jingchen Intelligent Identification Technology Co., Ltd.

Support Email : service@niimbot.com

Official Website : www.niimbot.com

Manufacturer's Address : No. 5, Creative Workshop, Creative World, Yezhihu West Road, Hongshan District, Wuhan, China

© 2024 NIIMBOT. All Rights Reserved.

NIIMBOT is a brand under Wuhan Jingchen Intelligent Identification Technology Ltd.