

TWO-IN-ONE WATER TANK

INSTALLATION & OWNER'S MANUAL



IMPORTANT NOTE:

Thank you very much for purchasing our product. Before using your unit, please read this manual carefully and keep it for future reference.

Safety Precautions

1. Please read these instructions carefully before installation and use. This manual contains the information necessary for the proper installation, commissioning, startup and maintenance of the equipment.
2. Please select the wiring cable specification according to the maximum current or maximum power.
3. Equipment installation, commissioning and maintenance must be completed by professionals.
4. Professionals must wear anti-static gloves when performing electrical operations.
5. Please regularly check the aging of components and lines, insulation and other problems, and make corresponding treatment when necessary.
6. Failure to follow the above instructions may cause equipment damage and even endanger personal safety.

Warning

1. Cut off the power supply before dismantling or repairing the equipment, otherwise there is a risk of electric shock.
2. The circuit connection must be reliable, otherwise it will cause short circuit and fire events.
3. All external connection wires must be protected by rubber or plastic rings when they pass through the sheet metal of the unit, otherwise there will be danger of electric shock.

CONTENTS

1. UNIT SPECIFICATIONS	1
1.1 Appearance	1
1.2 Notes	1
1.3 Parameters	2
2. INSTALLATION	3
2.1 Unit installation	4
2.2 Pipe connection diagram	5
2.3 Circuit connection	9
3. COMMISSIONING	9
3.1 Test run operation	9
4. MAINTENANCE	10

1. UNIT SPECIFICATIONS

1.1 Appearance

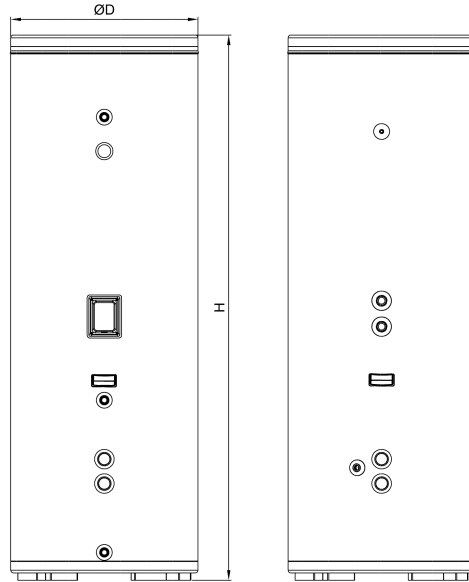

NO.Code	Model	Dimensions (diameter*height) (mm)	Net Weight (Kg)	Voltage Range
1	NE-F185WTC4-SA	Ø260 x 1895	56	220-240V~/50Hz
2	NE-F250WTC4-SA	Ø650 x 1895	87	220-240V~/50Hz
3	NE-F300WTC4-SA	Ø700 x 1895	98	220-240V~/50Hz

1.2 Notes

1. Please read these instructions carefully before installation and use. This manual contains the information necessary for the proper installation, commissioning, startup and maintenance of the equipment.
2. The manufacturer does not assume any responsibility for any personal injury or equipment damage caused by improper installation, commissioning, unnecessary maintenance, non-compliance with the provisions or instructions of this manual.
3. When the unit is not in use, please drain all the water inside the unit to avoid freezing the heat exchanger in winter.

1.3 Parameters

Model		NE-F185WTC4-SA	NE-F250WTC4-SA
DHW TANK			
Rated volume	L	185	250
Max. design pressure of water	Mpa	1	1
Max. safety Temp. on the water side	°C	95	95
Coil area of DHW pipe	m ²	0.84	1.8/2.8
Coil diameter of DHW	mm	Ø25	Ø25
Max. working pressure of the DHW tank coil	Mpa	1	1
Max. safe Temp. of the DHW tank coil	°C	110	110
Pressure drop of DHW coil	Mpa	0.092	0.092
Domestic hot water pipe connections	inch/cal	3/4	3/4
Dimension of the drainage socket	inch/cal	3/4	3/4
Dimension of the Temp. sensor	inch/cal	1/4	1/4
Electric heater rated power	kW	3	3
Electric heater voltage	V	220	220
Max. running current	A	13.7	13.7
BUFFER TANK			
Rated volume	L	80	100
Max. design pressure of water	Mpa	0.3	0.3
Max. safety Temp. on the water side	°C	95	95
Buffer tank pipe connections	inch/cal	5/4	5/4
Dimension of the drainage socket	inch/cal	3/4	3/4
Dimension of the Temp. sensor	inch/cal	-	-
DHW/BUFFER TANK			
Net dimensions	mm	Ø650×1895	Ø650×1895
Net weight	kg	56	87

Model	NE-F300WTC4-SA	
DHW TANK		
Rated volume	L	300
Max. design pressure of water	Mpa	1
Max. safety Temp. on the water side	°C	95
Coil area of DHW pipe	m ²	4.3
Coil diameter of DHW	mm	Ø32
Max. working pressure of the DHW tank coil	Mpa	1
Max. safe Temp. of the DHW tank coil	°C	110
Pressure drop of DHW coil	Mpa	0.092
Domestic hot water pipe connections	inch/cal	3/4
Dimension of the drainage socket	inch/cal	3/4
Dimension of the Temp. sensor	inch/cal	1/4
Electric heater rated power	kW	3
Electric heater voltage	V	220
Max. running current	A	13.7
BUFFER TANK		
Rated volume	L	125
Max. design pressure of water	Mpa	0.3
Max. safety Temp. on the water side	°C	95
Buffer tank pipe connections	inch/cal	5/4
Dimension of the drainage socket	inch/cal	1/2
Dimension of the Temp. sensor	inch/cal	-
DHW/BUFFER TANK		
Net dimensions	mm	Ø700×1895
Net weight	kg	98

2. INSTALLATION

2.1 Unit installation

2.1.1. Installation location

- a. The unit should be installed indoors with enough space for installation and maintenance;
- b. The unit should be installed in a ventilated place that can bear the weight of the unit, and can be installed horizontally without increasing mechanical noise and vibration.
- c. The installation location should be convenient for maintenance pipeline installation and electrical connection;

2.1.2. Attention

Installation is prohibited in the following locations

- a. Where there is mineral oil such as cutting oil;
- b. Seaside or other places that contain more salt in the air or water;
- c. Places where there are corrosive gases such as sulfur gas, acid or alkali, such as hot spring areas, etc.
- d. Kitchen or other places full of oil and gas and oil;

2.2 Pipe connection diagram

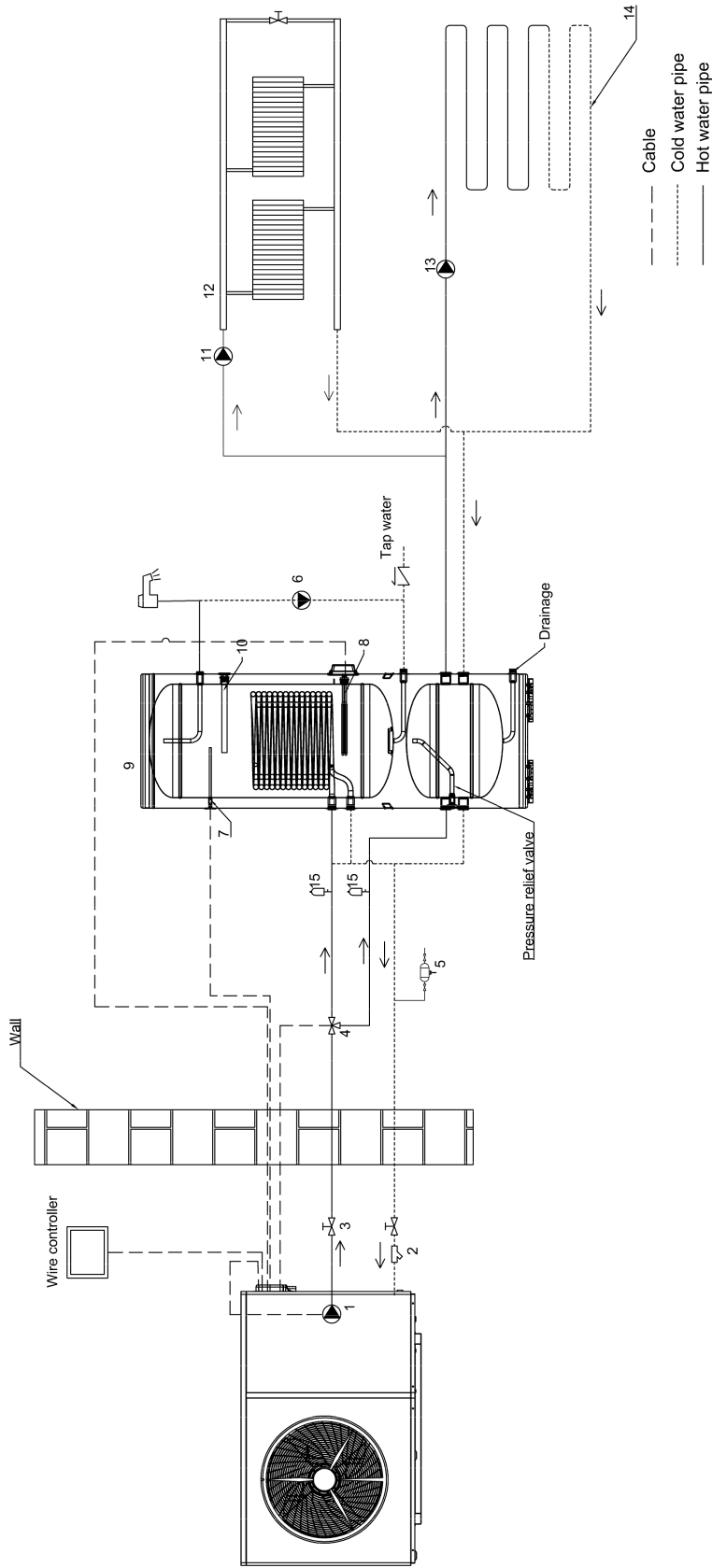

Heating&Cooling+Hot water Installation Instructions Schematic

NO.	Meaning	NO.	Meaning	NO.	Meaning	NO.	Meaning
1	Built-in water pump	4	Three-way valve	7	Water temperature sensor	10	Magnesium Anode
2	Y-type filter	5	Water refill valve	8	Electric heater	11	Water supply pump(Radiator)
3	Manual ball valve	6	Return water pump	9	Hybrid hot water tank	12	Radiator (Fan coil)
						13	Water supply pump(Floor heater)
						14	Floor heating loop
						15	Automatic Exhaust Valve

Specification of water tank ports

Model:NE-F185WTC4-SA

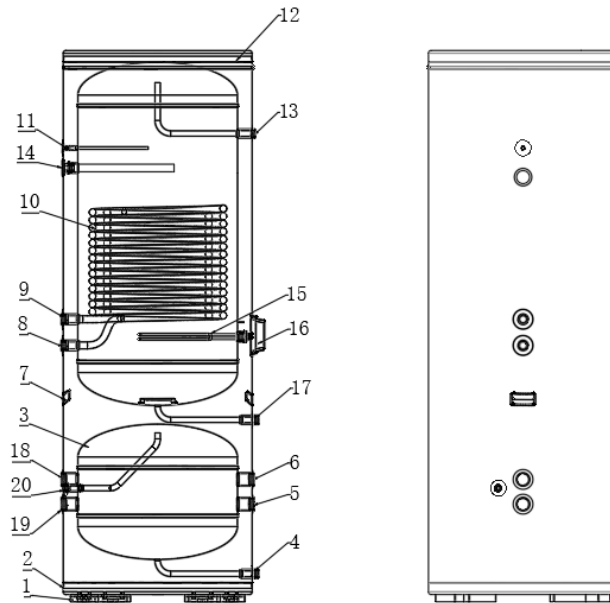

NO.	Meaning	Size	Quantity
1	Rubber pads		4
2	Chassis		1
3	Buffer tank inner		1
4	Drainage port	G 3/4 Female thread	1
5	Buffer tank water outlet	G1 1/4 Female thread	1
6	Buffer tank water inlet	G1 1/4 Female thread	1
7	Handle		2
8	Hot water tank outlet	G1 Female thread	1
9	Hot water tank inlet	G1 Female thread	1
10	Coiled tube	Ø25, 11meters	1
11	Water temp. sensor port	G1/4 Female thread	1
12	Top cover		1
13	Hot water output port	G3/4 Female thread	1
14	Magnesium Anode	G1 Female thread	1
15	Electric heater	G1 Female thread	1
16	Electric heater cover		1
17	Tap water inlet	G3/4 Female thread	1
18	Hot water outlet to devices	G1 1/4 Female thread	1
19	Cold water inlet from devices	G1 1/4 Female thread	1
20	Relief valve	G1/2 Female thread	1

Model:NE-F250WTC4-SA

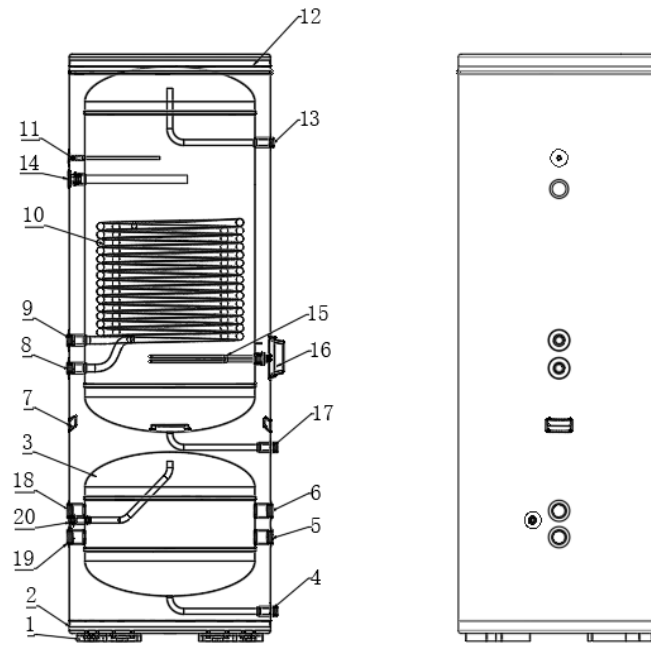

NO.	Meaning	Size	Quantity
1	Rubber pads		4
2	Chassis		1
3	Buffer tank inner		1
4	Drainage port	G 3/4 Female thread	1
5	Buffer tank water outlet	G1 1/4 Female thread	1
6	Buffer tank water inlet	G1 1/4 Female thread	1
7	Handle		2
8	Hot water tank outlet	G1 Female thread	1
9	Hot water tank inlet	G1 Female thread	1
10	Coiled tube	Ø25, 36meters	1
11	Water temp. sensor port	G1/4 Female thread	1
12	Top cover		1
13	Hot water output port	G3/4 Female thread	1
14	Magnesium Anode	G1 Female thread	1
15	Electric heater	G1 Female thread	1
16	Electric heater cover		1
17	Tap water inlet	G3/4 Female thread	1
18	Hot water outlet to devices	G1 1/4 Female thread	1
19	Cold water inlet from devices	G1 1/4 Female thread	1
20	Relief valve	G1/2 Female thread	1

Model:NE-F300WTC4-SA

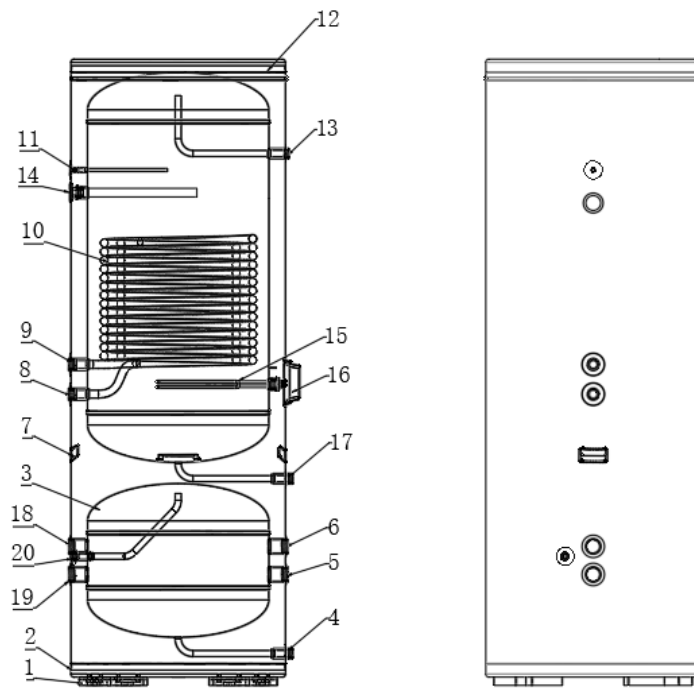

NO.	Meaning	Size	Quantity
1	Rubber pads		4
2	Chassis		1
3	Buffer tank inner		1
4	Drainage port	G 1/2 Female thread	1
5	Buffer tank water outlet	G1 1/4 Female thread	1
6	Buffer tank water inlet	G1 1/4 Female thread	1
7	Handle		2
8	Hot water tank outlet	G1 1/4 Female thread	1
9	Hot water tank inlet	G1 1/4 Female thread	1
10	Coiled tube	Ø32, 42.8meters	1
11	Water temp. sensor port 1	G1/4 Female thread	1
12	Top cover		1
13	Hot water output port	G1 Female thread	1
14	Magnesium Anode	G1 Female thread	1
15	Electric heater	G1 Female thread	1
16	Electric heater cover		1
17	Tap water inlet	G 3/4 Female thread	1
18	Hot water outlet to devices	G1 1/4 Female thread	1
19	Cold water inlet from devices	G1 1/4 Female thread	1
20	Relief valve	G1/2 Female thread	1

2.3 Circuit connection

2.3.1 General Precautions

- The unit must be powered by a dedicated power supply with the rated voltage.

Model	Power Supply Wires		
	Electricity Supply	Cable Diameter	Specification
NE-F185WTC4-SA	220-240V~/ 50Hz	3G 4.0mm ²	AWG 12
NE-F250WTC4-SA	220-240V~/ 50Hz	3G 4.0mm ²	AWG 12
NE-F300WTC4-SA	220-240V~/ 50Hz	3G 4.0mm ²	AWG 12

- Wiring work must be carried out by a professional staff in accordance with the wiring diagram on the unit.
- only electrical components specified by the Company may be used, as wiring that does not comply with electrical installation specifications may result in consequences such as controller malfunction or electric shock.
- Set up a good leakage protection device in accordance with the requirements of the relevant national technical standards for electrical equipment.
- All wiring construction is completed and carefully checked for errors before power is connected.
- Please do not attempt to repair the device yourself, as improper repair may result in electric shock or damage, etc.
- The power supply must be connected with an all-pole disconnecting device and a leakage protection device that matches the unit and has a contact opening distance of at least 3 mm from the power supply.
- if the power supply cord is damaged, to avoid danger it must be replaced by a professional from the designated manufacturer's service department or similar.
- switch off the power supply before opening the door of the electrical control box and do not remove or move any electrical components on the unit.
- When carrying out electrical operations, staff must wear anti-static gloves

3. COMMISSIONING

3.1 Test run operation

Precautions before test run operation:

1. The water system pipeline needs to be flushed and drained several times to ensure that the water quality and cleanliness meet the requirements. The pipeline system should be refilled with water and drained before turning on the water pump, and ensure that the water flow and outlet pressure meet the requirements.

The water quality should meet the requirements in the table

PH (25°C)	6.5-8.0	CL ⁻ (mg/L)	<50
Conductivity (25°C) (µs/cm)	<250	SO ₄ ²⁻ (mg/L)	<50
Fe (mg/L)	<0.3	Total Alkaline	<50
Hardness (mg/L)	<50	SiO ₂	<30

2. The test run only starts after all installations have been completed.
3. Please final check the following matters before the test run, and tick the box after confirmation..
 - The unit is installed correctly.
 - The supply voltage is the same as the rated voltage of the unit.
 - The piping and wiring are correct.
 - The air inlet and outlet of the unit are free from obstruction.
 - Drainage and evacuation are smooth and leak-free.
 - Leakage protector can operate effectively.
 - Pipe insulation is complete.
 - Grounding wires are properly connected.
4. Observe whether there is any leakage in the entire heating circulation system.

4. MAINTENANCE

Descaling

After a long-term operation, calcium oxide or other minerals may deposit on the surface of the water side heat exchanger. When these substances scale more, they will affect the heat exchange performance and lead to more power consumption, and high exhaust pressure (or low suction pressure).

Organic acids such as formic acid, citric acid and acetic acid can be used for cleaning. Never use cleaning agents containing chloric acid or fluoride, because the material of the water side heat exchanger is stainless steel, which is easy to be corroded.

Pay attention to the following aspects during the cleaning and descaling process:

- The cleaning of the water side heat exchanger must be carried out by a professional.
- After using the cleaning agent, clean the water pipes and heat exchanger with clean water for water treatment to prevent the system from being corroded or re-adsorbed after cleaning.

- When using cleaning agent, the concentration of the cleaning agent, the cleaning time and the water temperature should be adjusted according to the dirt deposits.
- After the cleaning of the acid solution is completed, the waste liquid needs to be neutralized, and contact the relevant company to deal with the waste liquid.
- Cleaning agents and neutralising agents are corrosive to the eyes, skin, nasal mucous membranes etc. Therefore protective devices (e.g. goggles, protective gloves, protective masks, protective footwear etc.) must be used during cleaning to prevent inhalation or contact with the agents.

Winter Shutdown

- When the unit is powered off, the water must be drained clean.
- When the unit is powered on, the water cannot be drained.

Initial start-up after shutdown

After any prolonged shutdown, the following preparations shall be made when the unit is started up again.

- Thoroughly inspect and clean the unit.
- Clean the plumbing system.
- Check the pressure relief valve and other equipment in the plumbing system.
- Fasten all electrical connections

Warning: During leak detection and air tightness test, never charge the refrigeration system with oxygen, acetylene, or other flammable or toxic gas, and only use high pressure nitrogen or refrigerant.

System antifreeze protection

If the flow passage of the water side heat exchanger freezes, it will cause serious damage and cause the heat exchanger to rupture and leak. Therefore, special attention should be paid to antifreeze.

- 1) When the unit is shut down for standby at a lower ambient temperature, if the unit is placed in an environment where the outdoor temperature is lower than 2 °C, the water in the water system should be drained.

116-06-10-00554